



PRODUCT NUMBER	34483
GTIN	6419410344835
E-NUMBER FI	3662656
TECHNICAL NAME	3x16A 400V 7.5kW
ETIM CLASS	EC000216

## MEASUREMENTS

HEIGHT	130 mm
WIDTH	96 mm
DEPTH	104 mm
VOLUME	1.2979 l
NET WEIGHT	0.4693 kg

## LOGISTICAL DATA

PACKAGE SIZE 1	170 mm
DEPTH	
PACKAGE SIZE 1	400 mm
HEIGHT	
PACKAGE SIZE 1	300 mm
WIDTH	
PACKAGE SIZE 1	0.4693 kg
WEIGHT	
PACKAGE SIZE 1	20.4 l
VOLUME	

## DIMENSIONAL DRAWING

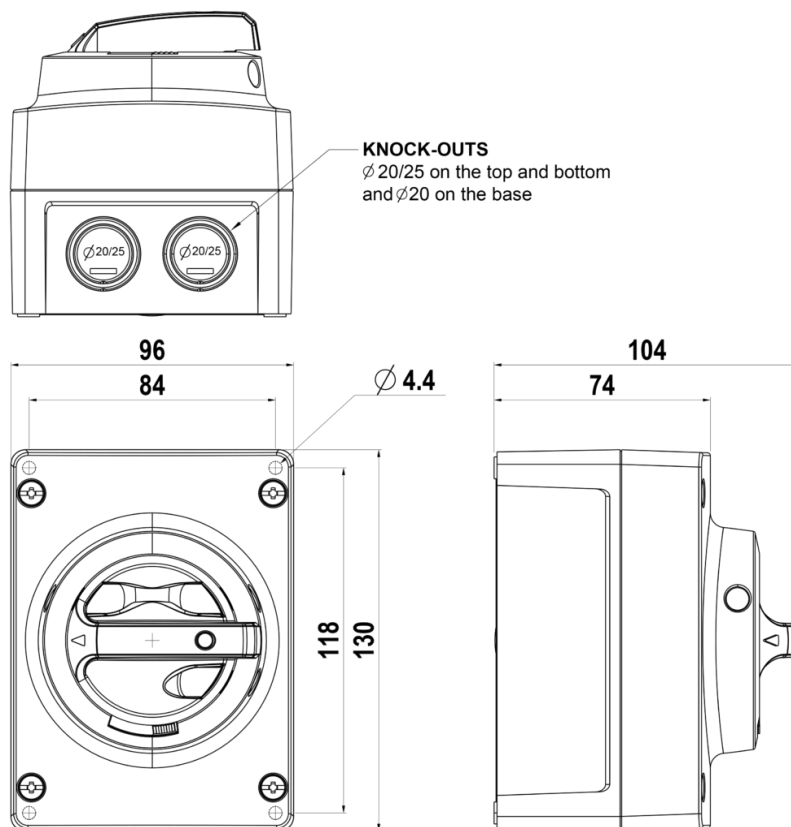

## TECHNICAL DATA

NUMBER OF POLES	3
ENCLOSURE	M2 (96 x 130 x 74 mm)
ENCLOSURE TYPE	Polycarbonate
UL	UL 60947-4-1A
EMC	No
ATEX	No
IP RATING	IP66
AMPERE RATING (600V)	16
HP 208V	3
HP 480V	7.5
HP 600V	10
SWITCH TYPE DESCRIPTION	Manual motor controller
AUXILIARY CONTACT TYPE	1NO
WIRE SIZE (CU ONLY)	14-8 AWG