

ISF 330NOUL M2

3x25A 400V 11kW



PRODUCT NUMBER	34471
GTIN	6419410344712
TECHNICAL NAME	3x25A 400V 11kW
ETIM CLASS	EC000216

MEASUREMENTS

HEIGHT	130 mm
WIDTH	96 mm
DEPTH	104 mm
VOLUME	1.2979 l
NET WEIGHT	0.4693 kg

LOGISTICAL DATA

PACKAGE SIZE 1 DEPTH	104 mm
PACKAGE SIZE 1 HEIGHT	130 mm
PACKAGE SIZE 1 WIDTH	96 mm
PACKAGE SIZE 1 WEIGHT	0.4693 kg
PACKAGE SIZE 1 VOLUME	1.2979 l

DIMENSIONAL DRAWING

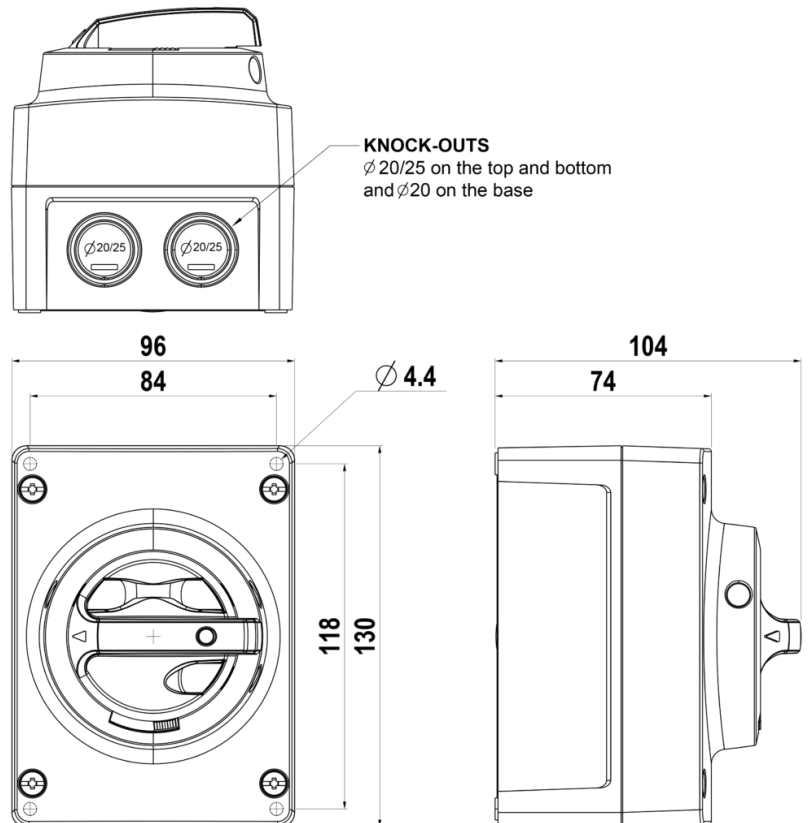

TECHNICAL DATA

NUMBER OF POLES	3
ENCLOSURE	M2 (96 x 130 x 74 mm)
ENCLOSURE TYPE	Polycarbonate
UL	UL 60947-4-1A
EMC	No
ATEX	No
IP RATING	IP66
AMPERE RATING (600V)	30
HP 208V	5
HP 480V	10
HP 600V	15
SWITCH TYPE DESCRIPTION	Manual motor controller
AUXILIARY CONTACT TYPE	1NO
WIRE SIZE (CU ONLY)	14-8 AWG