



ConnectSafe
KC1X16PE

PRODUCT NUMBER	35722
GTIN	6419410357224
E-NUMBER FI	1942010
ETIM CLASS	EC000897

MEASUREMENTS

HEIGHT	44 mm
WIDTH	13 mm
DEPTH	38.5 mm
VOLUME	0.022 l
NET WEIGHT	0.0589 kg

LOGISTICAL DATA

PACKAGE SIZE 1	100
PACKAGE SIZE 1 WEIGHT	0.0589 kg

DIMENSIONAL DRAWING

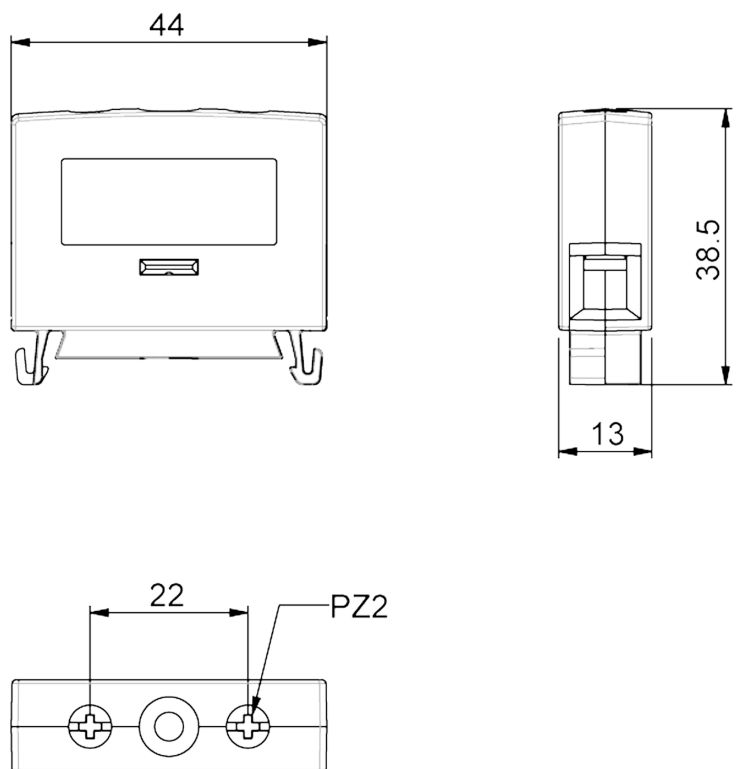

TECHNICAL DATA

ATEX	No
TORQUE AL/CU (NM)	1,8
KEY SIZE	PZ2
IN (CU) (A)	63
CU MM ²	1,5-16
NOMINAL VOLTAGE	800V AC