



## IsoSafe KSM 225 M1

PRODUCT NUMBER	37202
GTIN	6419410372029
ETIM CLASS	EC000216

### MEASUREMENTS

HEIGHT	128 mm
WIDTH	83 mm
DEPTH	56 mm
VOLUME	0.5949 l

### LOGISTICAL DATA

SALES UNIT	1
PACKAGE SIZE 1	1
PACKAGE SIZE 1 DEPTH	56 mm
PACKAGE SIZE 1 HEIGHT	128 mm
PACKAGE SIZE 1 WIDTH	100 mm
PACKAGE SIZE 1 VOLUME	0.7168 l
PACKAGE SIZE 2	8
PACKAGE SIZE 2 DEPTH	445 mm
PACKAGE SIZE 2 HEIGHT	135 mm
PACKAGE SIZE 2 WIDTH	110 mm
PACKAGE SIZE 2 VOLUME	6.6083 l

### DIMENSIONAL DRAWING

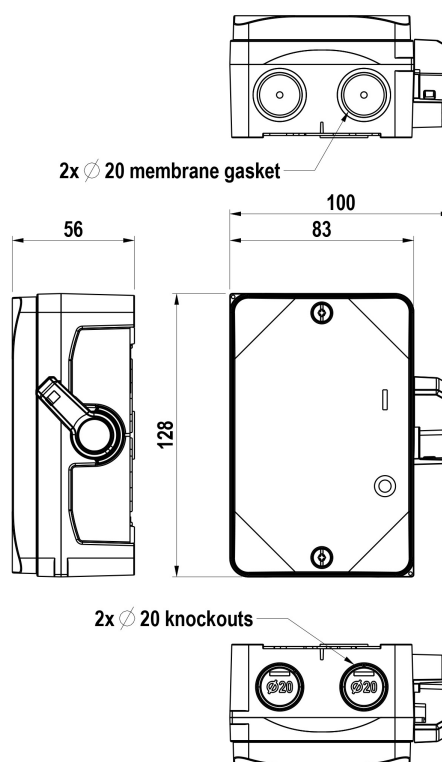

## TECHNICAL DATA

NUMBER OF POLES	2
ENCLOSURE	M1 (83 x 128 x 56 mm)
ENCLOSURE TYPE	Polycarbonate
EMC	No
IP RATING	IP67
RATED OPERATIONAL CURRENT AC-23A 415 V, IE (A)	25
RATED OPERATIONAL POWER, 1- PHASE 1500 RPM SQUIRREL-CAGE MOTOR AC-23A 240 V (KW)	4
RATED INSULATION VOLTAGE, UI (V)	800
SWITCH TYPE DESCRIPTION	Isolating switch
NOMINAL VALUES WITH CABLE SIZE (MM <sup>2</sup> )	4
RATED THERMAL CURRENT, ITH (A)	25
RATED THERMAL CURRENT (ENCLOSED), ITHE (A)	25
RATED OPERATIONAL CURRENT AC-21A 415 V, IE (A)	25
RATED OPERATIONAL CURRENT AC-23A 240 V, IE (A)	25
RATED IMPULSE WITHSTAND VOLTAGE, UIMP (KV)	8
RATED SHORT-CIRCUIT MAKING CAPACITY, ICM 415 V (KA)	1.6
RATED SHORT-TIME WITHSTAND CURRENT 1 S, ICW 415 V (KA)	1.1
RATED BREAKING CAPACITY, AC- 23A 415 V (A)	200
ELECTRICAL ENDURANCE (NUMBER OF OPERATIONS)	3000

MECHANICAL ENDURANCE (NUMBER OF OPERATIONS)	20000
TERMINAL / BOLT SIZE CU (MM <sup>2</sup> )	1,5..16
MAXIMUM TERMINAL TORQUE (NM)	1.8
SWITCH TYPE	Load Break Switch