



 IsoSafe

KEM 380CUL M3

3x63A 400V 30kW

PRODUCT NUMBER	35184
GTIN	6419410351840
TECHNICAL NAME	3x63A 400V 30kW
ETIM CLASS	EC000216

MEASUREMENTS

HEIGHT	190 mm
WIDTH	144 mm
DEPTH	96 mm
VOLUME	2.6266 l
NET WEIGHT	0.835 kg

DIMENSIONAL DRAWING

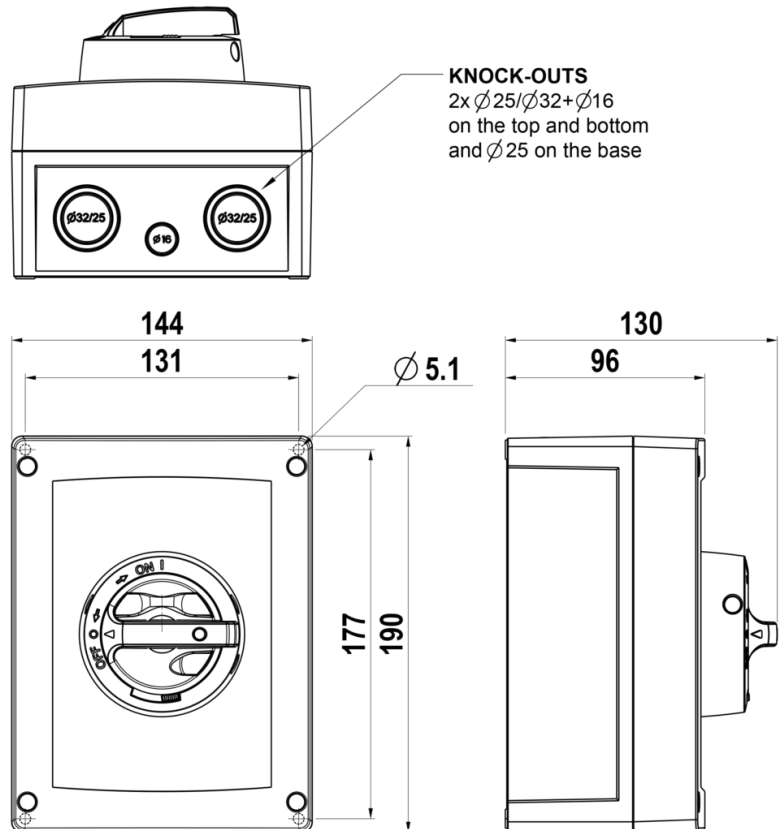

LOGISTICAL DATA

PACKAGE SIZE 1 DEPTH	108 mm
PACKAGE SIZE 1 HEIGHT	262 mm
PACKAGE SIZE 1 WIDTH	162 mm
PACKAGE SIZE 1 WEIGHT	0.835 kg
PACKAGE SIZE 1 VOLUME	4.584 l

TECHNICAL DATA

NUMBER OF POLES	3
ENCLOSURE	M3 (144 x 190 x 96 mm)
ENCLOSURE TYPE	Polycarbonate
UL	UL 60947-4-1A
EMC	No
ATEX	No
IP RATING	IP66
AMPERE RATING (600V)	80
HP 208V	10
HP 415V	15
HP 480V	30
HP 600V	30
SWITCH TYPE DESCRIPTION	Manual motor controller
WIRE SIZE (CU ONLY)	12-4AWG