



PRODUCT NUMBER	34437
GTIN	6419410344378
E-NUMBER FI	3662664
TECHNICAL NAME	3x16A 400V 7.5kW
ETIM CLASS	EC000216

MEASUREMENTS

HEIGHT	158.5 mm
WIDTH	104 mm
DEPTH	80 mm
VOLUME	1.3187 l

LOGISTICAL DATA

PACKAGE SIZE 1 DEPTH	80 mm
PACKAGE SIZE 1 HEIGHT	158.5 mm
PACKAGE SIZE 1 WIDTH	104 mm
PACKAGE SIZE 1 VOLUME	1.3187 l

DIMENSIONAL DRAWING

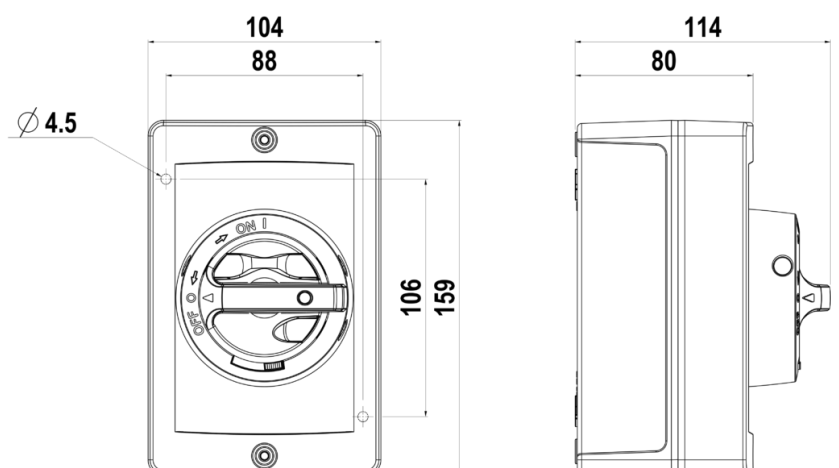
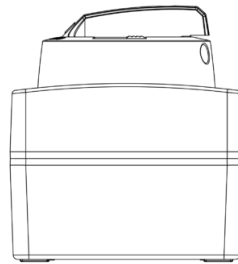

TECHNICAL DATA

NUMBER OF POLES	3
ENCLOSURE	A2 (104 x 159 x 80 mm)
ENCLOSURE TYPE	Aluminium
UL	UL 60947-4-1A
EMC	No
ATEX	No
IP RATING	IP66
AMPERE RATING (600V)	16
HP 208V	3
HP 480V	7.5
HP 600V	10
SWITCH TYPE DESCRIPTION	Manual motor controller
AUXILIARY CONTACT TYPE	1NO
WIRE SIZE (CU ONLY)	14-8 AWG